

OPTIONS

RS232 Optical Fiber



With this option, HV CONCEPT power supplies can be controlled through a optical fiber kit.



▶ OPTIC FIBER KIT

- A complete solution to insure an insulated remote control
- Includes an adapter for computer/PLC (USB powered)
- Fiber optics supplied (25 meters in standard, more lengths available)
- USB and RS232 cables supplied (3 meters each)
- Analogic 0-10V remote connector still available
- Requires RS232 option
- Replace the SubD 9 points RS232 connector

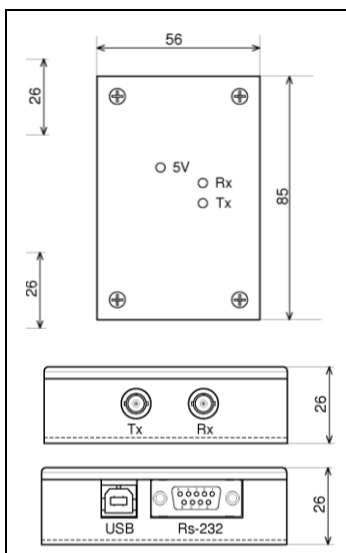
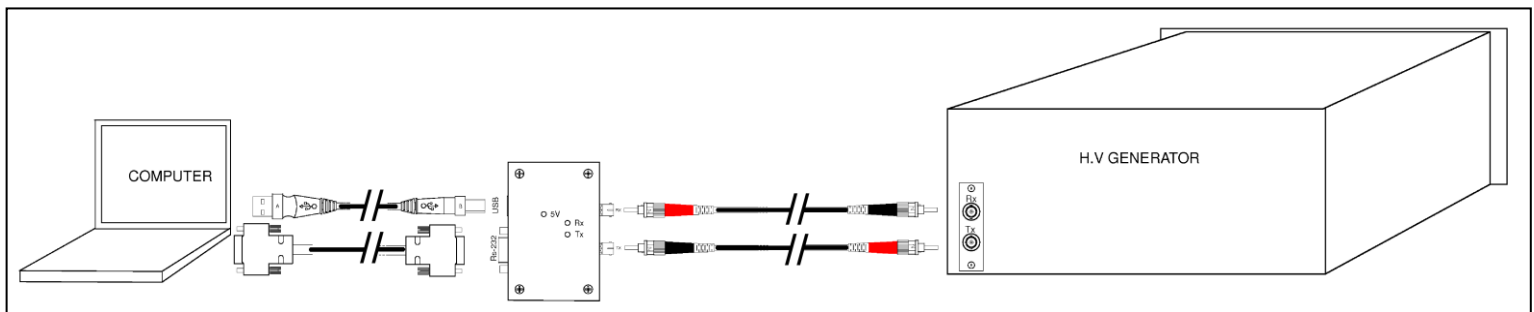

With this option, 0 V reference of External Control is completely insulated from Chassis Ground (insulation > 100 kV/meter of fiber).

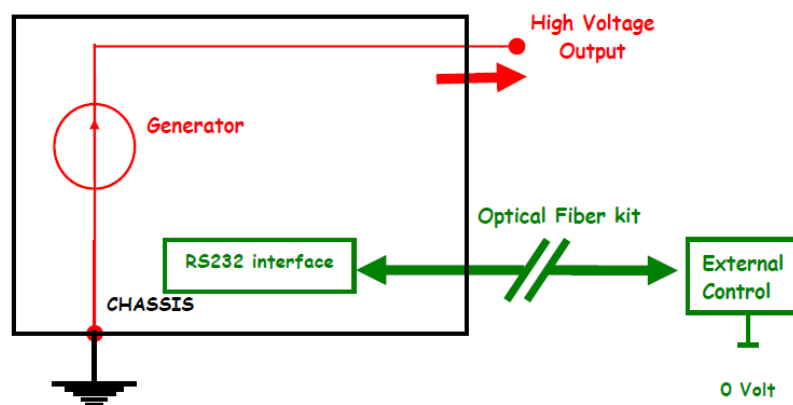

Complete Insulation between Power Supply and its External control

Optical fiber kit consists in is 2 Transmitter/Receiver and 25 m optical cable (one integrated in the generator). It has to be used in conjunction with RS232 interface (option: RS232).